

4

3

2

1

ISOMETRIC VIEW

EXTERIOR DIMENSIONS:
 LENGTH: 244"
 WIDTH: 98"
 HEIGHT: 106.5"

B

B

A

A

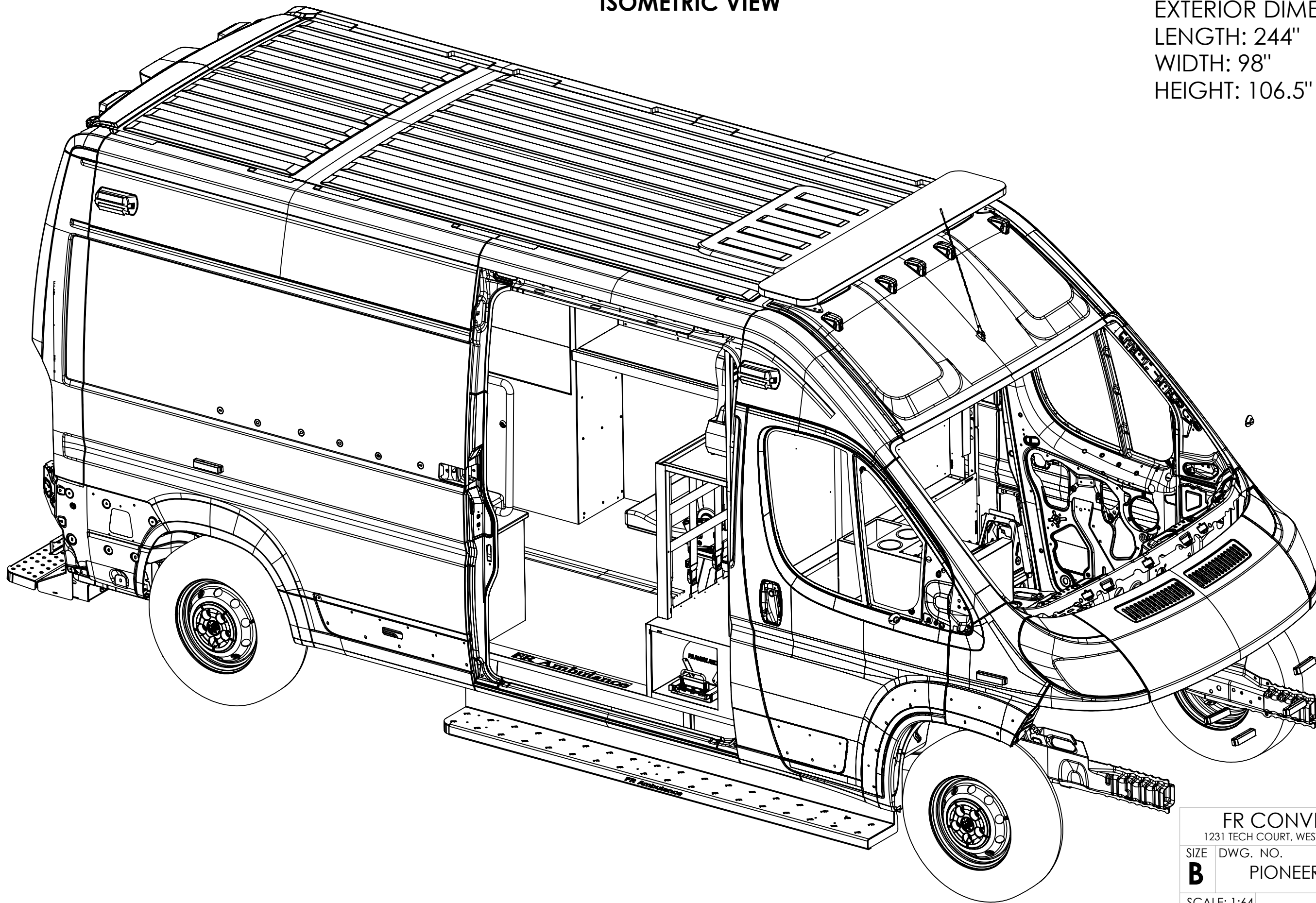

FR CONVERSIONS		
1231 TECH COURT, WESTMINSTER, MD 21157		
SIZE	DWG. NO.	REV
B	PIONEER II	A
SCALE: 1:64		SHEET 1 OF 4

4

3

2

1

4

3

2

1

REAR VIEW

TIE IN HVAC SYSTEM

DIGITAL SAFE

110V OUTLET

12V OUTLET

BAG STORAGE

STAIR CHAIR STORAGE

BACKBOARD STORAGE

[967.36]
38.09
[AISLE WIDTH]

FR Ambulance

FR CONVERSIONS		
1231 TECH COURT, WESTMINSTER, MD 21157		
SIZE	DWG. NO.	REV
B	PIONEER II	A
SCALE: 1:64		SHEET 2 OF 4

4

3

2

1

B

B

A

A

STREET SIDE VIEW INTERIOR

4

3

2

1

ENCLOSED CABINETS

ACTION AREA

CENTER CONSOLE

B

B

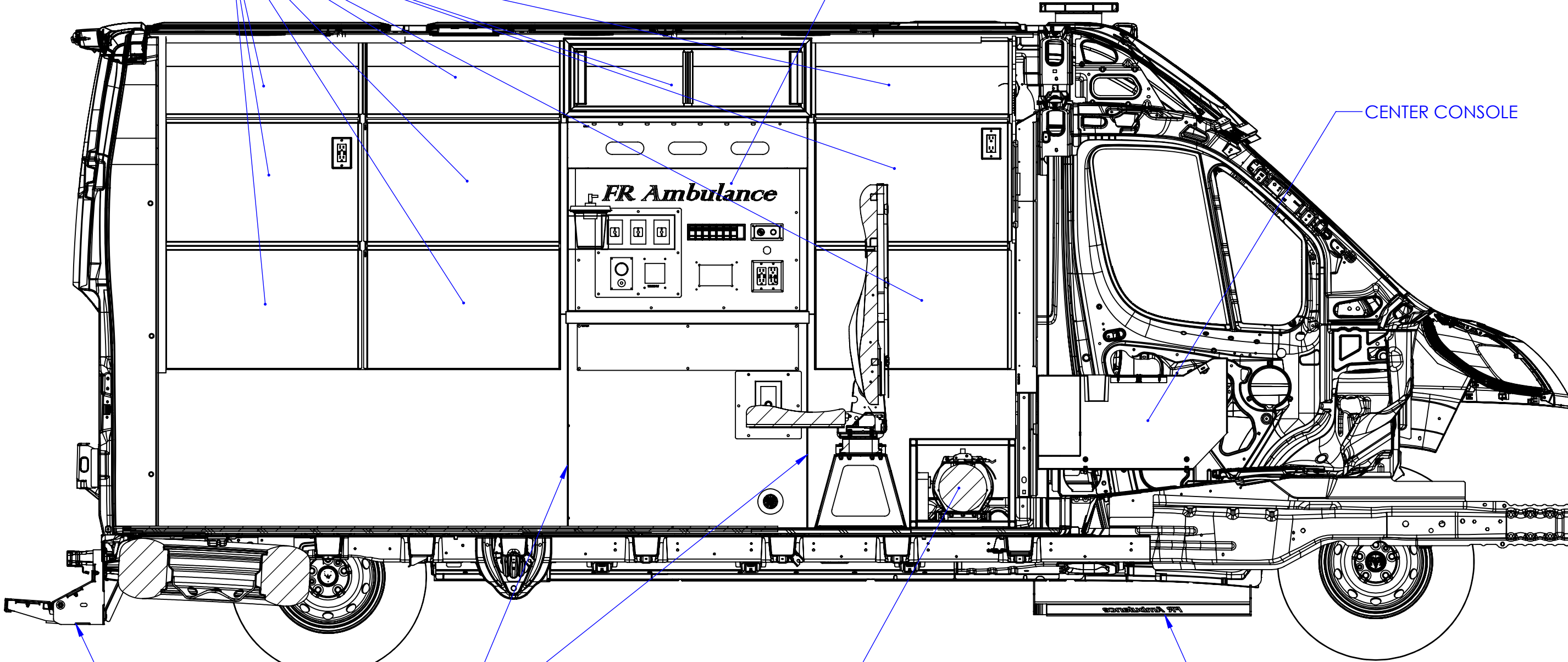

BATTERY, INVERTER, BREAKER, SUCTION, EXHAUST STORAGE AREA

MAIN OXYGEN TANK STORAGE

STREET SIDE AND CURB SIDE RUNNING BOARDS

FLIP UP REAR STEP

4

3

2

1

A

A

FR CONVERSIONS		
1231 TECH COURT, WESTMINSTER, MD 21157		
SIZE	DWG. NO.	REV
B	PIONEER II	A
SCALE: 1:64		SHEET 3 OF 4

4

3

2

1

CURB SIDE VIEW INTERIOR

OXYGEN/SUCTION OUTLET

6PT RESTRAINTS

110V OUTLET

CEILING GRAB RAIL

SIDE DOOR GRAB RAIL

REAR DOOR GRAB RAIL

[2389.87]
94.09
[SEAT TO REAR DOOR]

FR CONVERSIONS		
1231 TECH COURT, WESTMINSTER, MD 21157		
SIZE	DWG. NO.	REV
B	PIONEER II	A
SCALE: 1:64		SHEET 4 OF 4

4

3

2

1

B

B

A

A

