

4

3

2

1

ISOMETRIC VIEW

EXTERIOR DIMENSIONS:
 LENGTH: 244"
 WIDTH: 98"
 HEIGHT: 110"

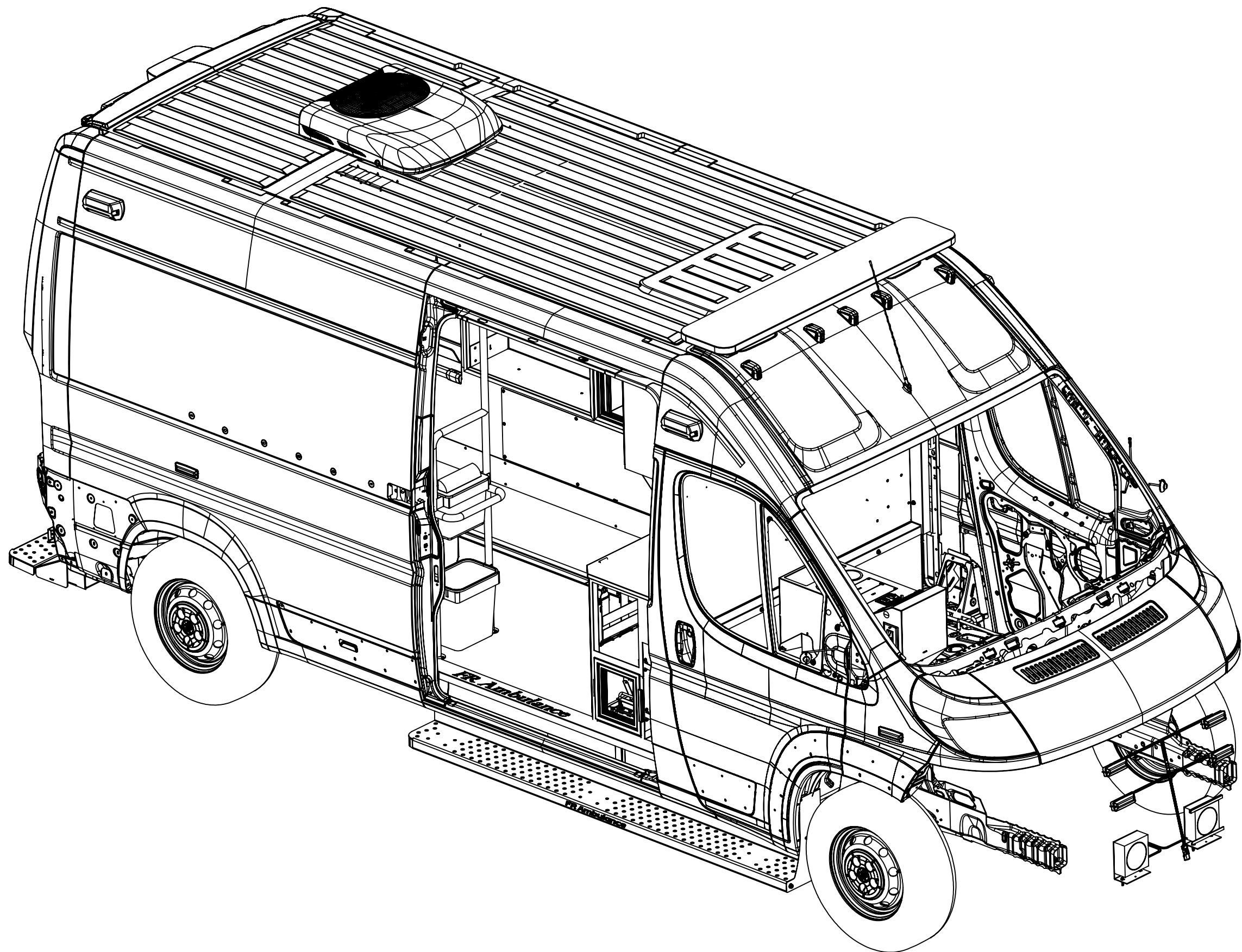

FR CONVERSIONS		
1231 TECH COURT, WESTMINSTER, MD 21157		
SIZE	DWG. NO.	REV
B	PIONEER II XL	A
SCALE: 1:48		SHEET 1 OF 1

4

3

2

1

4

3

2

1

REAR VIEW

ROOFTOP AUXILIARY AC UNIT

UPPER STREET SIDE
(MINIMUM) CABINET DEPTH [228.60]
9.00

FOLDING CAPTAINS CHAIR
(OPTIONAL INTERGRATED
CHILD SEAT)

[1911.76]
75.27
[FLOOR TO CEILING]

LOWER STREET SIDE
(MAXIMUM) CABINET DEPTH [266.70]
10.50

[1125.40]
44.31
[MIN AISLE WIDTH]

[1288.30]
50.72
[MAX AISLE WIDTH]

FR CONVERSIONS		
1231 TECH COURT, WESTMINSTER, MD 21157		
SIZE	DWG. NO.	REV
B	PIONEER II XL	A
SCALE: 1:64		SHEET 1 OF 1

4

3

2

1

B

B

A

A

4

3

2

1

STREET SIDE VIEW INTERIOR

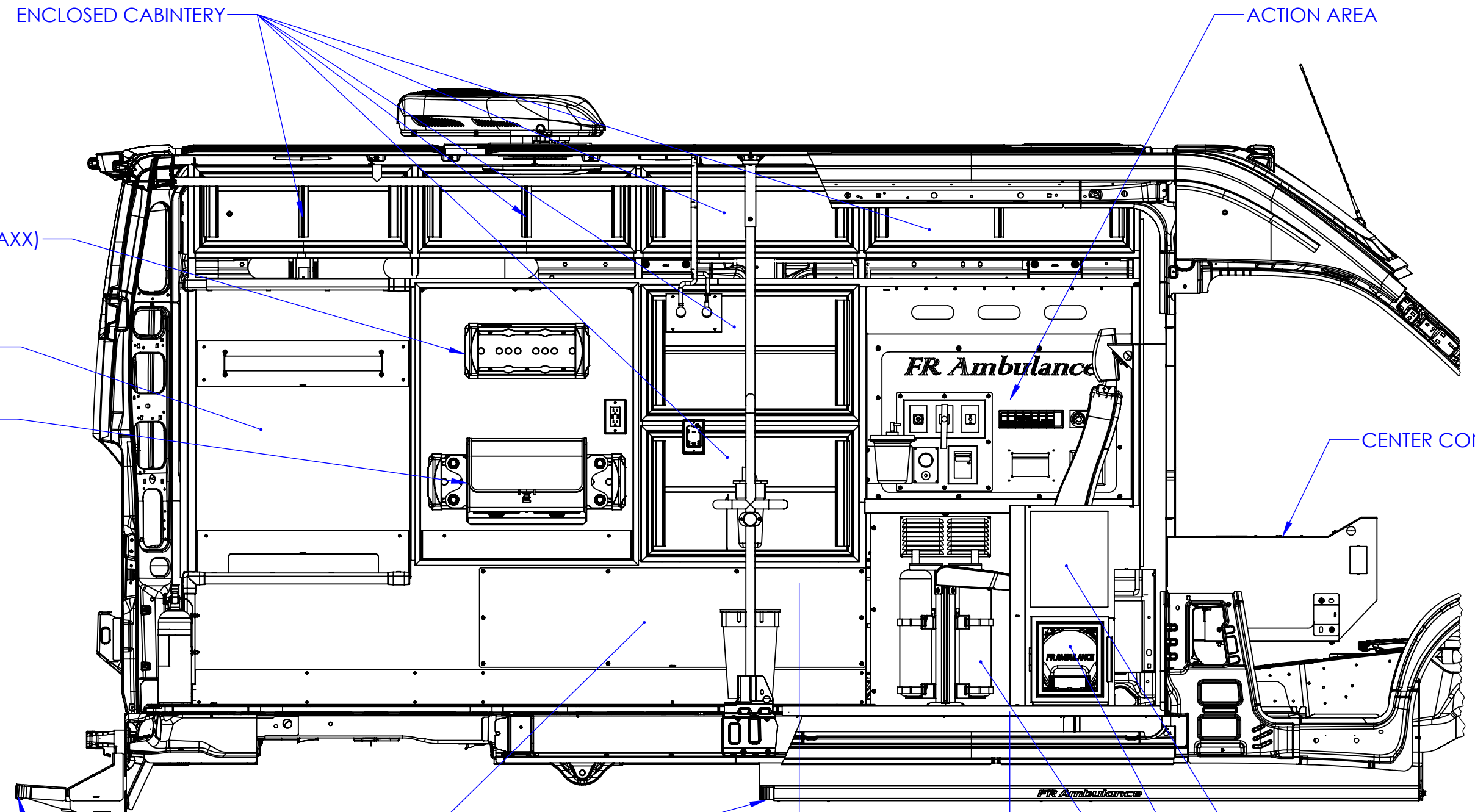

ENCLOSED CABINTRY

ACTION AREA

MONITOR MOUNT (INTRAXX)

STAIR CHAIR STORAGE

INTRAXX FLEX SPACE

FR Ambulance

CENTER CONSOLE

BATTERY, INVERTER, BREAKER,
SUCTION ACCESS PANEL

[730.78]
28.77
[SIDE DOOR OPENING]

BAG STORAGE

MAIN OXYGEN CYLINDER STORAGE

PORTABLE OXYGEN TANK STORAGE

STANDARD REAR FLIP UP STEP
AND CURB SIDE AND STREET
SIDE RUNNING BOARDS

FR CONVERSIONS		
1231 TECH COURT, WESTMINSTER, MD 21157		
SIZE	DWG. NO.	REV
B	PIONEER II XL	A
SCALE: 1:64		SHEET 1 OF 1

4

3

2

1

4

3

2

1

CURB SIDE VIEW INTERIOR

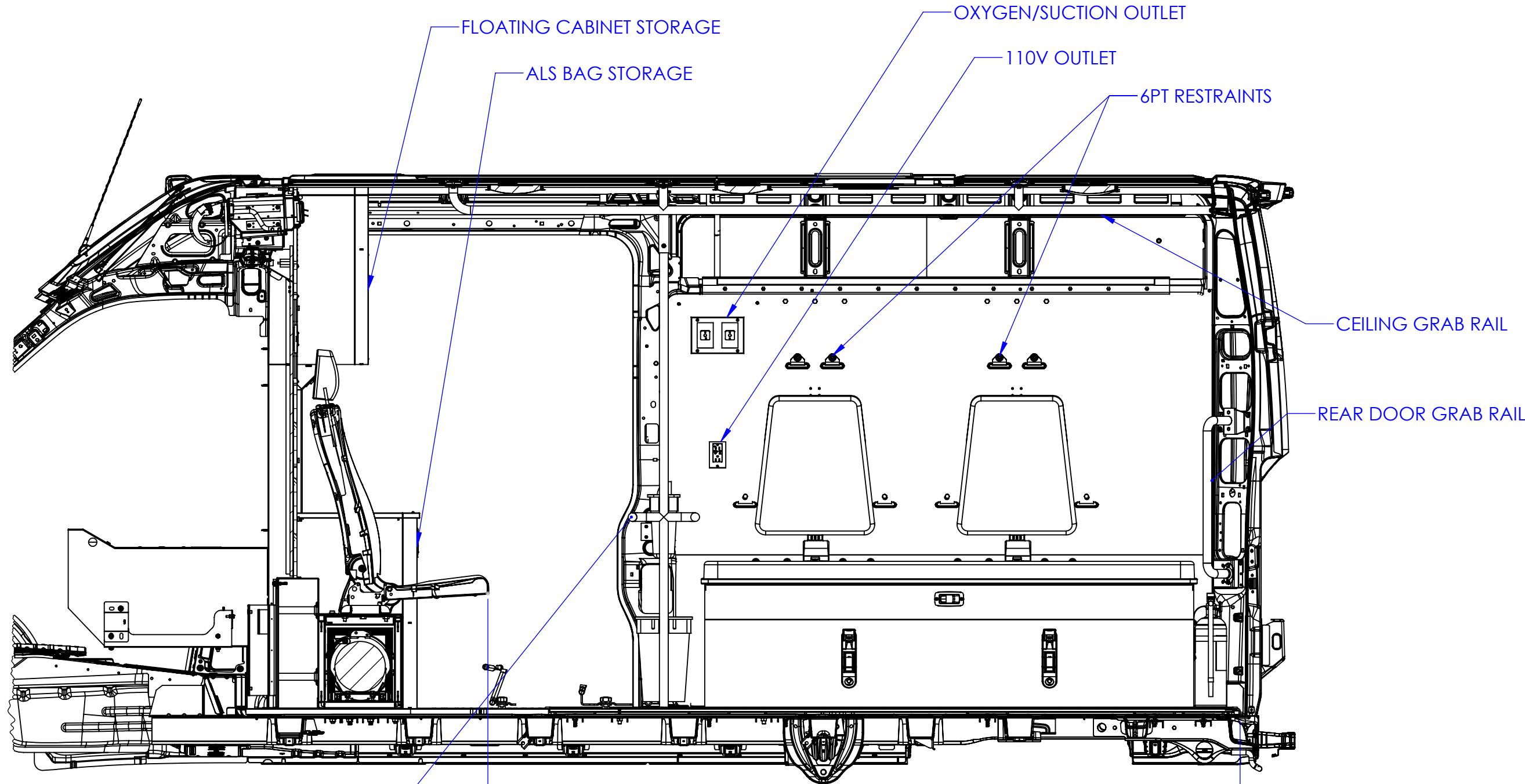

FLOATING CABINET STORAGE

ALS BAG STORAGE

OXYGEN/SUCTION OUTLET

110V OUTLET

6PT RESTRAINTS

CEILING GRAB RAIL

REAR DOOR GRAB RAIL

GRAB RAIL W/ INTEGRATED SHARPS AND WASTE

[2745.27]
108.08
[SEAT TO REAR DOORS]

FR CONVERSIONS		
1231 TECH COURT, WESTMINSTER, MD 21157		
SIZE	DWG. NO.	REV
B	PIONEER II XL	A
SCALE: 1:64		SHEET 1 OF 1

4

3

2

1

B

B

A

A

4

3

2

1

BULKHEAD VIEW

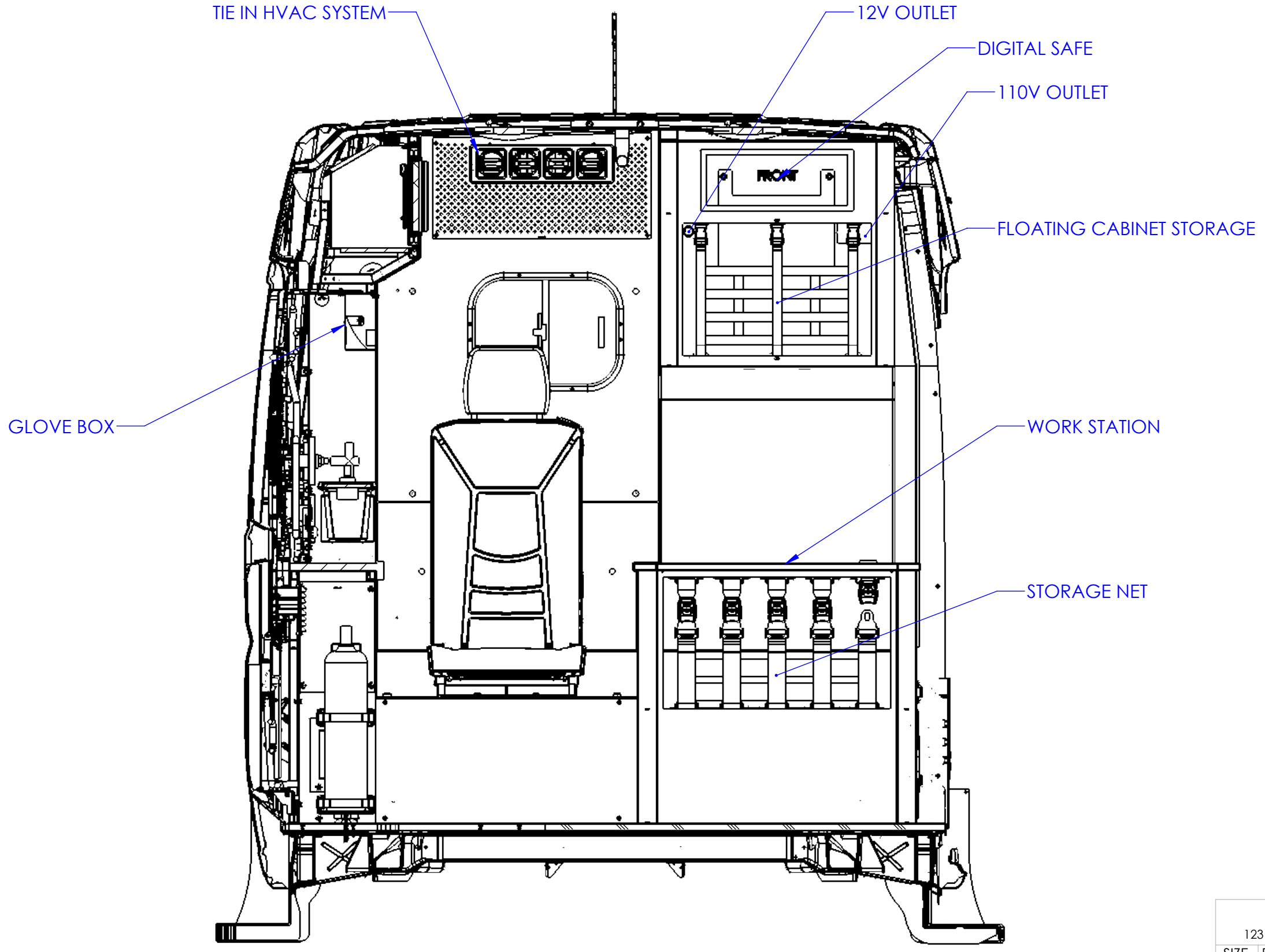

B

B

A

A

FR CONVERSIONS		
1231 TECH COURT, WESTMINSTER, MD 21157		
SIZE	DWG. NO.	REV
B	PIONEER II XL	A
SCALE: 1:48		SHEET 1 OF 1

4

3

2

1